

# **Is there anyone who has installed photovoltaic panels**





## Is there anyone who has installed photovoltaic panels

---



### Building regulations for solar panels: explained [UK, 2024]

Your solar panel system has to be isolated from your mains electricity, so engineers are able to safely perform maintenance and servicing whenever your system needs ...

### Installing Domestic Solar Panels UK: Your Legal Questions Answered

The issue with installing self-made DIY solar panels is that many of these certified engineers will refuse to certify solar panel units that they did not personally install. In ...



### Utility-Scale ESS solutions



### Solar panel myths: five common concerns about solar ...

Read more: our guide to solar panel installation. 4. There isn't enough sun for solar panels. Nearly seven in 10 solar panel owners we surveyed have had no technical problems with their solar panel system since it was installed. Among ...

### New planning rules to boost solar rollout and slash energy bills

Homes and businesses will be able to install rooftop solar panels more easily, under new rules announced today. Changes to permitted development rights rules will mean ...



### How are solar panels installed? , 11 steps explained

In this guide, we'll explain a typical solar panel installation from start to finish, as well as what all the hardware does, and where on your property you can install the panels. If you're interested in how much you could save ...

### Solar panels: Are they worth it? - MoneySavingExpert

There are now 1.5 million solar panels on homes across the UK. As well as saving you money on energy bills, solar panels can earn you cash. And don't worry, they can still generate electricity on gloomy days, vital when ...



### 9 Problems With Solar Panels On Roofs And How To Address Them

The inverter is a critical component of a solar panel system as it converts the direct current (DC) produced by the panels into alternating current (AC) that can be used to ...



### Transparent Solar Panels: Reforming Future Energy Supply

This clear solar panel could turn virtually any glass sheet or window into a PV cell. By 2020, the researchers in the U.S. and Europe have already achieved full transparency ...



### Government Solar Panel Help In 2024 (Inc Schemes)

The scheme is open to anyone who has installed a solar panel system of up to 5MW capacity. To qualify for payments the system must have been installed by an MCS ...

### Solar Panel Installation FAQs: Your Top Questions Answered

Sources and references: 1 Finance is subject to eligibility, terms and a £500 deposit. 0% APR fixed over 36 months.. 2 These annual energy savings are dependent on ...

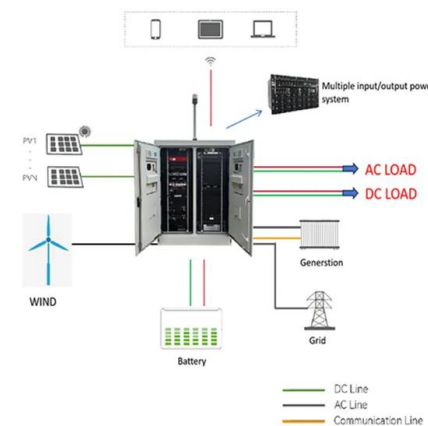

### Solar Panel Wiring Basics: Complete Guide & Tips to Wire a PV ...

There is a solar panel wiring combining series and parallel connections, known as series-parallel. Aside from helping you properly install the PV system, it is a great ...



## Installing Solar Panels: Solar PV Installation in Ireland

The truth is anyone can do a solar panel installation and you do not need to be specially qualified to hook up your solar panel system to your electricity to benefit from solar ...



## Solar panels UK: The complete guide , The Independent

Solar panels harness energy from the sun, converting it to free renewable electricity. In the past, it took as many as 14 years for homeowners to break even on the best solar panels. The good news

## How are solar panels installed? A step-by-step guide

How solar panels are installed . Solar panels are typically installed on the roof, which means that the shape and orientation of the latter should be studied beforehand. Just as ...



## Solar Panel Building Regulations and SAP calculations, UK Guide

There are a large number of formally approved solar panel installations in conservation areas, including on roofs that face the road. and the regulations you need to ...



## Can You Put Solar Panels On A Conservatory Roof?

More than 1.3 million UK households now have solar panels. A typical three-bedroom home will save up to £454 a year on its energy bill with a solar panel system. Solar ...



## Solar panel grants and funding in the UK 2024 , FMB

Reduced upfront costs: Solar panel grants lower the initial investment required for solar panels, making renewable energy more accessible to a wider range of households.; Enhanced return on investment: By ...



## Homeowner's Guide to the Federal Tax Credit for Solar Photovoltaics

Solar PV panels or PV cells (including those used to power an attic fan, but not the fan itself)  
Contractor labor costs for onsite preparation, assembly, or original installation, including ...



## [Solar Panel Problems And How To Solve Them](#)

Solar panel inverter problems, dirty solar panels, pigeon problems under solar panels, generation meter and electrical problems with solar PV, and much more at your ...





### All you need to know about powering your home with solar panels

Most home solar panel systems are installed within two or three days and should last for up to 25 years without needing much maintenance. o Get payments for extra energy you generate It's ...



### Are Solar Panels Harmful To Your Health?

The primary risk of chemical exposure occurs if a solar panel is damaged or begins to degrade with age. If the protective layers are compromised, hazardous materials like ...



### Grants for solar panels: what Government help is available

This and a few other previous grants for solar panels have now ended, and the primary aid available today is the ECO4 scheme. There's a couple of other schemes that will ...



### The pros and cons of solar panels

Since there aren't any moving parts inside a solar panel, they are completely silent - a far cry from the racket of many types of small generators. 5. They can reduce your ...





### Solar panel installation

Use our solar panel buying advice and see our solar panel brand reviews to help make your decision. What is the best angle and roof direction for solar panels? The table below shows the percentage of the ...

### FLEXIBLE SETTING OF MULTIPLE WORKING MODES



### Solar Panels Grants and Funding UK (November 2024)

Solar panel grants like the ECO4 scheme can help consumers get free solar panels in the UK.; Currently, there is 0% VAT on solar panels, batteries, and other renewable ...

### The 10 best solar panel grants UK , Eligibility checker [2024]

2 ???· 415,172 solar panel systems have signed up for an SEG tariff since the scheme launched in January 2020, according to Ofgem data. In the same time frame, 450,531 solar ...



### INTEGRATED DESIGN

EASY TO TRANSPORT AND INSTALL,  
FLEXIBLE DEPLOYMENT



### Solar panel installation

Getting solar panels installed isn't as disruptive as you might think. When we surveyed solar panel owners in April 2024, many said the process was relatively easy. In fact 80% of them told us they would install solar panels ...



## Solar Panel Sizes & Dimensions UK (2024)

2. Are there any government grants available for solar panel installation in the UK? Answer: As of now, there are no direct government grants for solar panel installations for ...



### **Solar Panel Battery Storage: Can You Save Money Storing ...**

If you have solar PV panels, or are planning to install them, then using home batteries to store electricity you've generated will help you to maximise the amount of renewable energy you ...

## **Contact Us**

---

For catalog requests, pricing, or partnerships, please visit:  
<https://vdbconstruction.co.za>