

Solar db box





Solar db box



AC Distribution Box (ACDB) , Key Role in Solar Power Setups

In the world of electrical systems, an AC Distribution Box (ACDB) plays a key role in solar power setups. To grasp how electrical systems are managed and made safe and ...

Solar DCDB

Rectangle solar dc db box, 4-7.5 kw Matrix 2 in 2 out dcdb box, voltage: 1000v, 15a Solar string monitoring unit, 125kwp Mild steel 25-30kw 1 in 1 out acdb with nvr, 6, automation g 50 hz solar dcdb 1in 1out, 500 v Ip65 polycarbonate 25a ...



CBI Din Rail Solar Distribution Board 8KW SOLARDB8

Optimize your solar power distribution with the CBI Din Rail Solar Distribution Board 8KW SOLARDB8. Advanced solution ensures efficient and reliable management. If this product is purchased and no stock is available, our team will contact you with the option of a

Solar Db Box Wiring , Solar Distribution Box Connection , Db

In this video I have Provided Solar DB Box Wiring with Details. Solar Distribution Box Connection not Difficult, if you Follow Diagram db Box Wiring and Connection are Easy For DB box and



HPL India Presents

HPL India offers distribution boxes for different purposes. These boxes are best in class and well known for its quality. View Detail DC Distribution box The DC distribution unit is used to collect the DC output from Array Junction Box (AJB) and supply it to the inverter.



ACDB/ DCDB Box for Solar Power System (Explained)

When you explore these devices, you will come across phrases such as single phase and three phase. If the solar power system capacity is between 1kW to 6kW, it will require a single-phase ACDB and single-phase DCDB box. A single-phase ACDB and DCDB



What is ACDB and DCDB: Their Importance in Solar Panels

In solar panel systems, a DCDB, or Direct Current Distribution Box, serves as a vital component in managing the flow of electricity generated by the solar panels. Essentially, ...





ACDB/ DCDB Box for Solar Power System (Explained)

This box protects your solar inverter and panels from high voltage and short circuits. A DCDB box contains a DC SPD to protect against surges, a DC MCB, and a fuse that breaks the circuit in case of high voltages.



Solar Distribution Board - 5kW

12-Way Sub DB Box. In conclusion, the AC Protection Box incl Changeover - Deye 5KW Hybrid Inverter is more than a product; it's a comprehensive, secure, and efficient solution for your solar power setup.



MORA Solar Distribution Box

Pure Plastic Material: Ensures long-lasting durability and resistance to impact and corrosion. The MORA Solar Distribution Box combines functionality with a robust design, making it an ...



Single Phase DB Box Wiring: Your Ultimate Guide!

Wiring a single-phase distribution board (DB) box is a fundamental task for ensuring that electrical circuits within a residential or commercial space are safely and efficiently managed. This process includes mounting the distribution board, installing circuit breakers





Customized Solar ACDB boxes at best price in India

All around India, we provide customized ACDB boxes. Technically, we manufacture Solar ACDBs according to our standard design and tailor them as per the customer's needs. The ACDB (AC Distribution Box) is used to protect the Solar Inverter from any form



[Solar DCDB & ACDB Price \[2024\] , Solar Experts](#)

Junction Boxes provide extra electrical protection to the solar system during failures. Solar DCDB provides the interconnection between the input string from the solar panels, and the output ...

Understanding the Role of AC DB Box in Solar Plants

An AC DB (Distribution Board) box, also known as an AC Combiner Box, is a crucial component in a solar power system. It acts as a central hub that distributes the ...

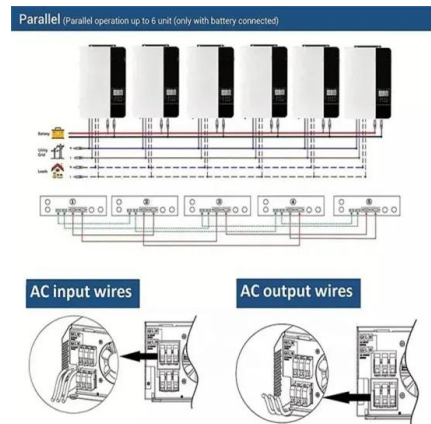

Buy Solar ACDB DCDB Collection , Direct Manufacturer

Kenbrook Solar ACDB Box Single Phase 32A 320V SPD Havells, Indicator with 1 in 1 Out DCDB Box 600V SPD, 20A MCB Havells for Solar Panels (1Ph 32A HVL IND Combo) INR 4,999.00 Original price was: INR 4,999.00. INR 3,790.00 Current price is: INR 3,790.00.



Daystar Solar -DC Distribution Box 2 IN 2 OUT (5Kw-8Kw)

Daystar Solar 2 in 2 out DCDB Box Protect Your Solar Power System with a Reliable DC Distribution Box A DC Distribution Box (DCDB), also known as a Direct Current Distribution Box, is an essential component of any solar power system. It receives the direct



[System wiring of a solar installation](#)

Greetings people of the forum! I have been planning my solar power system for a while now and purchased most of the components. The installation is 100% DIY, so I am going solo on trying to figure things out. Now I am at the point where I need to map out how the

Mce Cb1-1 Complete Solar Db Board - 1 In 1 Out PV Combiner Box

Mce Cb1-1 Complete Solar Db Board - 1 In 1 Out PV Combiner Box SKU: SA-ONE-1110 Categories: Combiner Box, Electrical Brand: Onesto R 3,299.00 Original price was: R3,299.00. R 1,999.00 Current price is: R1,999.00. inc VAT 2 in stock 4 Items sold in

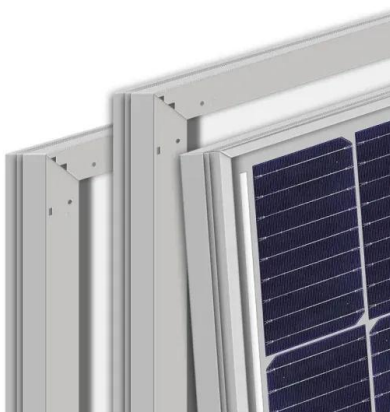

[Solar DCDB & ACDB Price \[2024\] . Solar Experts](#)

Price of Solar ACDB, Solar DCDB, Surge Protection Device, earth fault protection, IP 65& 67, Reverse Protection and fuses, 1KW to 100 KW We supply all across India, including states such as Haryana(Gurgaon, Faridabad, Karnal, Sonipat, Panipat, Hisar, Sirsa



Solar on-grid Dual string DC Distribution Box with 1000V

DCDBs expect 2 string of PV panels up to maximum of 19 no's in series. The DCDB is connected between PV panels and the on-grid inverter. Max PV voltage is 1000 V. Max PV current is 10 A ...



[FS 8Way Plastic Surface DB Box - SunMagic](#)

8Way PVDB -8 Solar Distribution Box Easy installation of surface mounting boxes - can be installed at 180 . Cable entry and wiring optimized. More wiring space between modular devices and terminals, and behind the DIN rails. Neat and ...

Distribution Box Price In Pakistan , Electrical Solar DB Box

A distribution box, is also known as a DB box like Solar DB Box, Main Home DB Metal Box. it's a very important component in electrical systems. It serves as a central hub for distributing electrical power from the main source to different circuits within a building.



Green Meter Metal Disconnect Box Solar DB Box - Alladin Store

The Green Meter Solar DB Box is a high-quality distribution box designed for solar power systems. It is built to manage and distribute electrical power from solar panels to various parts of a building. The box is made from durable, weather-resistant materials, ensuring it can withstand harsh outdoor conditions. It feat



DB box price in Pakistan

A distribution box, also known as a DB box, is a crucial part of installing electrical wiring since it acts as a hub from which cable routes branch out to various switches and outlets located throughout a building. So let us talk about the DB box price in Pakistan.



Solar Db Box Wiring , Solar Distribution Box Connection , Db

Solar Distribution Box Connection not Difficult, if you Follow Diagram db Box Wiring and Conn In this video I have Provided Solar DB Box Wiring with Details.

[What is a Solar Distribution Box?](#)

In this blog, you will discover what a Solar Distribution Box is and what role it plays in a Solar power plant installation. For the installation of a Solar power plant (rooftop system) the Direct ...



[Solar DB Board or Solar Distribution Board](#)

Discover our Solar DB Board. Learn how a Solar Distribution Board optimize your solar installation, offering efficient energy management Our AC Protection Box with Changeover - Your Gateway to Uninterrupted Power! For use on 5kw inverters. A typical



13P DB Box Pixel (Economical Quality)

13P DB Box Pixel (Economical Quality) is a cost-effective distribution box for up to 13 circuit breakers. It's designed for residential and small commercial use, featuring durable construction, a neutral finish, and easy wall mounting. This compact box efficiently manages electrical circuits.



Waterproof DB Boxes -- Solartastic

SOLARTASTIC is a supplier of quality solar power kits and Solar Energy Products that can be trusted to provide dependable performance for your business. We understand the importance of reliability and quality, which is why we ensure that everything we offer is of the highest quality at affordable rates. Our reputation



Distribution Boxes-Purpose and Benefits , October 26, 2024

DB Box helps us expand our solar system by adding more panel strings and connecting them through the distribution box. Conclusion A distribution box is a crucial component in a solar power system. It contributes to increasing the system's efficiency, safety



AC/DC Power Distribution Box 16 Way - Solarshop Pakistan

DESCRIPTION SHLX-PV4/1 DC combiner box is suitable for inverter (MAX input voltage DC550V/DC1000V, 4 PV input channel, 1 output channel, single MPPT inverter). Box body is made of PVC engineering materials, with test for fire retardant, temperature rise





[DB Boxes & Circuit Breakers for Sale](#)

We stock a range of DB Boxes & Circuit Breakers from well-known brands offering quality Electrical Supplies for sale. Shop Electrical Supplies from Buco today! Which DB boards are best to buy? A distribution board (also known as panelboard, breaker panel, or electric panel) is a component within the electricity supply system that divides an electrical power feed into ...



Contact Us

For catalog requests, pricing, or partnerships, please visit:
<https://vdbconstruction.co.za>