

Why is it better to install photovoltaic panels in commercial housing

Sample Order
UL/KC/CB/UN38.3/UL





Overview

What are the benefits of installing solar panels on commercial buildings?

The benefits of installing solar panels on commercial buildings extend beyond just reducing electricity bills. By embracing solar energy, businesses can achieve substantial cost savings, reduce their environmental impact, and enhance their corporate image.

Are commercial solar panels better than residential solar panels?

They can be installed to power both industrial processes and offices and can lead to substantial cost savings. Commercial solar panels are typically more powerful (400W-600W) than the solar panels used for domestic purposes (250W-400W), averaging 195cm x 99cm in size, compared to 167cm x 101cm for residential panels.

Are commercial solar panels a good investment for your business?

The maintenance costs for commercial solar panels is low, too. Keep the panels clear and free of debris and they'll continue to generate clean and cheaper power for 25-30 years. Another great reason to install solar panels for your business is the Smart Export Guarantee (SEG).

Should you install solar panels on commercial buildings?

Installing solar panels on commercial buildings promotes energy independence. By generating their own electricity, businesses become less reliant on the power grid and are less susceptible to fluctuations in energy prices. This independence is particularly valuable during times of high demand or when grid electricity is disrupted.

Why should your business install solar panels?

Another great reason to install solar panels for your business is the Smart Export Guarantee (SEG). Businesses with solar panel systems that have a capacity of 5 megawatts (MW) or less are allowed to sell energy back to the



UK's National Grid.

Are solar panels a good investment?

In fact, solar panels have the potential to cover a substantial portion or even the entirety of a building's energy needs. Over time, the investment in solar panels pays off, as they typically have a lifespan of 25-30 years and require minimal maintenance. 2. Environmental Impact The environmental benefits of solar energy cannot be overstated.



Why is it better to install photovoltaic panels in commercial housing



New planning rules to boost solar rollout and slash ...

Homes and businesses will be able to install rooftop solar panels more easily, under new rules announced today. Changes to permitted development rights rules will mean more homeowners and

Commercial Solar Panel Installation

Solar Panel Installation for Businesses. If you're a business owner or any other organisation in the commercial sector looking to make the switch to green energy, our commercial solar panel ...



LFP 12V 100Ah

Why solar is win-win for landlords and tenants , Journals

Overlaying the forecast solar generation profile onto Flamingo's energy usage data indicated that most of the solar generation would be consumed on site, minimising the ...

Solar Panel In Malaysia: Should You Install This For ...

The pricing can depend on the installation's size, the solar panel's quality, and the particular scheme or company that you engage for the service. Analysts suggest that a standard residential installation could vary ...



Why Solar PV Is the Way to Go: Lower Bills and Big Eco Benefits

Solar PV is an energy source that uses photovoltaic panels to convert sunlight into electricity. This type of power generation can be used to reduce our dependence on traditional fossil fuel ...



A Guide to Commercial Solar Panel Installation

Investing in commercial solar panels is a significant step towards sustainability and cost savings for businesses. Understanding the installation process can help you navigate the journey more ...



Commercial Solar Panel Installation: How To Make Use of It

The solar panel industry is gaining recognition with the improved collective understanding of Earth's limited natural resources. More and more households are investing in ...

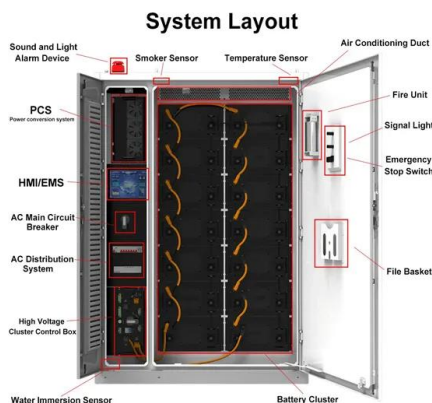



The complete guide to commercial solar panels

Why should you install solar panels? Commercial solar panels are a popular choice for large-scale solar installations, such as those used to power industrial facilities. They can be installed to power both industrial ...



Solar Panel Battery Storage: Can You Save Money ...

If you have solar PV panels, or are planning to install them, then using home batteries to store electricity you've generated will help you to maximise the amount of renewable energy you use. Storing your solar energy ...

How do solar cells work? Photovoltaic cells explained

Two main types of solar cells are used today: monocrystalline and polycrystalline. While there are other ways to make PV cells (for example, thin-film cells, organic cells, or perovskites), monocrystalline and ...



[Are Solar Panels On New Builds A Must?](#)

Installing solar panels is a great way to decrease your property's dependence on the National Grid and fossil fuels. The Energy Saving Trust estimates the average UK home ...



Commercial Solar Panel Installation , Infinity Energy Services

Real Estate and Housing Developments:
Incorporating solar panels into new residential
and commercial developments can increase
property values and appeal to environmentally ...



APPLICATION SCENARIOS



Residential Solar Panels and Battery Storage: A Complete Guide

We then delved into designing and installing
solar panel systems, maximising efficiency and
performance, and exploring financial
considerations and incentives. Moreover, ...

Commercial Solar Panels in the UK: Guide (November 2024)

Simply fill in one simple, 30-second form to
receive up to 4 free, non-binding quotes from
commercial solar panel installers in your area.
Reliable local installers can keep ...



Install Solar Panel for Housing Society and Apartment Complexes

Enjoy free electricity by installing solar panel in
housing society, resident welfare associations,
and apartment buildings at the best prices.
Reduce electricity bills for common areas with a
...



Homeowner's Guide to Going Solar , Department of Energy

Also, your solar energy system will undergo a thorough inspection from a certified electrician as part of the installation process. A working PV panel has a strong encapsulant that prevents ...



A Full Guide to Photovoltaic Panel Installation and Maintenance

Site Evaluation for Photovoltaic Panel Installation. Before embarking on a solar panel installation project, selecting the appropriate site for the panels is crucial. A proper site ...



Commercial Solar Panels in UK

Commercial Solar Panel Installation. Regardless of the scale of your operations, you can reap all the benefits of renewable energy by installing solar panels on your commercial property. For instance, utilizing a sustainable power ...



Residential Solar PV Panels Ireland

PV generation are the leading supplier and installer of residential solar PV panels in Ireland. Find out why you should go solar and see how much you could save! is an energy performance ...

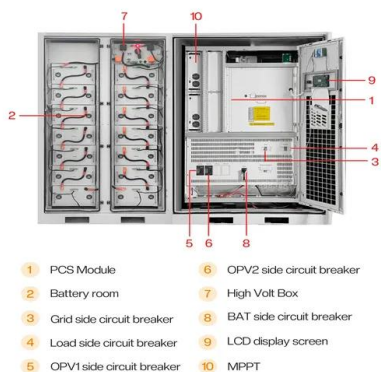



Why Tier 1 Solar Panels Are Best Choice For Your Home

Commercial. Commercial Solar Panel; Commercial Air Source Heat Pumps; Housing Developments; Finance; Case Studies; About us; Blog; Free Quote; This means they can convert more sunlight into usable ...



Solar Panel Wiring Basics: Complete Guide & Tips to Wire a PV ...

Photovoltaic (PV) systems are one of the most important renewable energy sources worldwide. Learning the basics of solar panel wiring is one of the most important tools ...

Solar Panels in Malaysia: Simple Incentives and Regulation Guide

Estimated Reading Time: 5 minutes As the demand for solar panels continues to grow, many homeowners are drawn to the benefits of solar energy roof systems, including ...

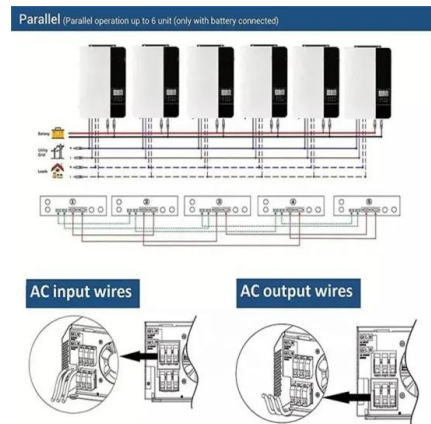

Why Do Consumers Choose Photovoltaic Panels? Identification ...

The results of structural equation modeling showed that only functional value and environmental value had a positive impact on consumers' choice behavior toward photovoltaic ...



Solar Panels for New Builds: A UK Guide for 2024

Most solar panel installations should last for more than 25 years with the right maintenance, and the initial cost can normally be offset within the first 5-10 years. Most of ...



Pros and cons of solar panels: They're usually worth it

If you finance your solar panel installation with a zero-down loan, you can even start saving right away. These panels may cost a bit more, but they are better for the ...

Things to know when buying a house with solar panels

An entire solar panel is made up of 36 to 72 solar cells. Based on the total electricity consumption per day, choose the right panel and number of panels to suit your ...

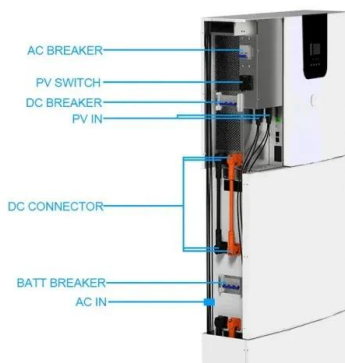

Rooftop solar on commercial property (Part 1 of 2): ...

The installation of rooftop solar panels, particularly on commercial premises, has been on the rise over the last decade. This trend has been pushed by a combination of factors, including the commercial and social ...



Commercial Solar Panel Installations in the UK: A Comprehensive ...

3 ???· The cost of commercial solar panel installations in the UK varies based on the scale of the project and the type of technology used. On average, a commercial solar system may cost ...



The Ultimate Guide to Commercial Grade Solar Panels: ...

The superior performance characteristics of commercial solar panels translate into enhanced energy production and long-term cost savings. With higher power output and efficiency ratings, these panels can generate more electricity per ...

Commercial Solar PV , Solar Panels for Commercial Buildings

Commercial Garages; Housing Associations; To arrange a free site survey and quote for commercial solar panel installation, call our team today on Battery storage is the perfect ...



Contact Us

For catalog requests, pricing, or partnerships, please visit:
<https://vdbconstruction.co.za>